

CE EPA ISO9001

YOUR BEST PARTNER TODAY & TOMORROW

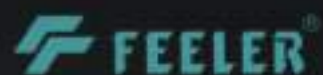

FEELER FORKLIFT COUNTER BALANCE DIESEL FORKLIFT

5-10ton



友嘉實業集團
FAIR FRIEND ENT. GROUP.

Main Specifications

Characteristics	1.1	Manufacturer	FEELER	FEELER	FEELER	FEELER	FEELER	FEELER			
	1.2	Model	FD50TA	FD50TA	FD70TA	FD80TA	FD100TA	FD100TA			
	1.3	Power	diesel	diesel	diesel	diesel	diesel	diesel			
	1.4	Load capacity	kg	5000	6000	7000	8000	10000			
	1.5	Operation type	seat	seat	seat	seat	seat	seat			
	1.6	Load center	mm			600					
Tires	1.7	Service weight	kg	8340	8840	9350	10960	12510			
	2.1	Tire	pneumatic	pneumatic	pneumatic	pneumatic	pneumatic	pneumatic			
	2.2	Tire size, front	8.25-15-14PR	8.25-15-14PR	8.25-15-14PR	9.00-20-14PR	9.00-20-14PR	9.00-20-14PR			
	2.3	Tire size, rear	8.25-15-14PR	8.25-15-14PR	8.25-15-14PR	9.00-20-14PR	9.00-20-14PR	9.00-20-14PR			
	2.4	Wheels, number front/rear	4/2	4/2	4/2	4/2	4/2	4/2			
	3.1	Mast obliquity, forward/backward	deg	6/12	6/12	6/12	6/12	6/12			
Dimensions	3.2	Overall Length (without fork)	L2 mm	3430	3430	3530	3800	4200			
	3.3	Overall width	b mm	1995	1995	1995	2165	2165			
	3.4	Height of the back rest	h4 mm	1350	1380	1380	1580	1580			
	3.5	Max. lifting height	h mm			3000-6000 option					
	3.6	Height of overhead guard (cable)	h3 mm	2485	2485	2485	2580	2580			
	3.7	Ground clearance with load of mast	mm	200	200	250	200	200			
Performance	3.8	Min. right-angle aisle width	mm	3000	3000	3080	3310	3540			
	3.9	Min. turning radius (outer)	Wa mm	3250	3300	3450	3700	3950			
	4.1	Travel speed, with/without load	km/h	26/28	26/28	26/28	26/28	26/28			
	4.2	Lifting speed, with/without load	mm/s	370/500	350/500	350/500	380/410	310/410			
	4.3	Lowering speed, with/without load	mm/s	400/375	400/375	400/375	400/375	400/375			
	4.4	Climbing ability	%	20	20	20	21.2	21.2			
Engines	4.5	Service brake	Hydraulic	Hydraulic	Hydraulic	Hydraulic	Hydraulic	Hydraulic			
	5.1	Manufacturer of engine	CHAOCHAI	YUCHAI	ISUZU	PERKINS	CHAOCHAI	YUCHAI	ISUZU	PERKINS	
	5.2	Engine type	6102B04	6106G6C	A-68G1QC-02	1104D-E44T	6102B06	6105G6C	A-68G1QC-02	1104D-E44T	
	5.3	Rated power	Kw	81	85	82.4	75	81	85	82.4	75
	5.4	Rated rotate speed	Rpm	2500	2400	2000	2200	2500	2400	2000	2200
	5.5	Number of cylinders/displacement	-cc	6/5785	6/6494	6/6494	4/4400	6/5785	6/6494	6/6494	4/4400
Other	5.6	Fuel consumption to VDI	g/kWh	231	220	232	234	231	220	232	234
	6.1	Fuel tank capacity	L		120			140			
	6.2	Working pressure for attachments	Mpa		17			17			

*Modification of technical details will be saved to our company with no additional notice to client.

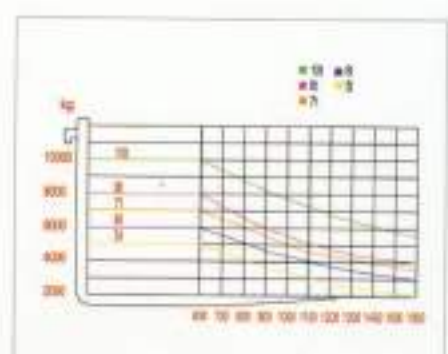
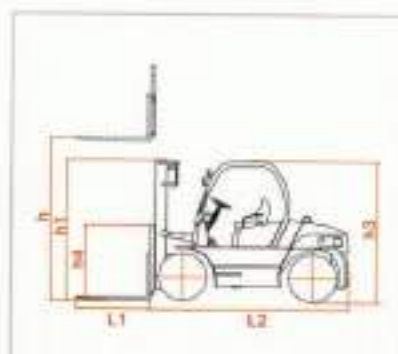
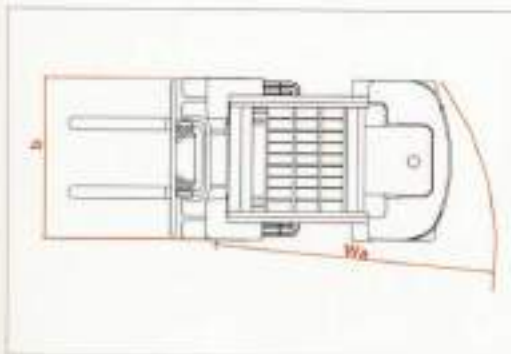

Mast standard															
Model	Mast fork height		Load capacity (load center 500mm) kg					Overall height (ht) mm					Free lift (mm)	Free lift (mm)	Tilt Range
	mm		FD50TA	FD60TA	FD70TA	FD80TA	FD100TA	FD50TA	FD60TA	FD70TA	FD80TA	FD100TA	5-7T	8-10T	Freeback
2-STAGE MAST	S250	2500	5000	6000	7000	8000	-	2250	2250	2375	2450	-	-	-	6°-12°
	S270	2700	5000	6000	7000	8000	-	2350	2350	2475	2550	-	-	-	6°-12°
	S300	3000	5000	6000	7000	8000	10000	2500	2500	2625	2700	2850	-	-	6°-12°
	S330	3300	5000	6000	7000	8000	10000	2650	2650	2775	2850	3000	-	-	6°-12°
	S350	3500	5000	6000	7000	8000	10000	2750	2750	2875	2950	3100	-	-	6°-12°
	S375	3750	5000	6000	7000	8000	10000	2875	2875	3000	3075	3225	-	-	6°-12°
	S400	4000	5000	6000	7000	8000	10000	3050	3050	3175	3250	3400	-	-	6°-12°
	S425	4250	5000	6000	7000	8000	10000	3175	3175	3300	3375	3525	-	-	6°-12°
	S450	4500	5000	6000	7000	8000	10000	3300	3300	3425	3500	3650	-	-	6°-12°
	S475	4750	5000	6000	7000	7750	10000	3425	3425	3550	3625	3775	-	-	6°-6°
	S500	5000	5000	6000	7000	7750	10000	3550	3550	3675	3750	3900	-	-	6°-6°
	S550	5500	4750	5700	6600	7400	9000	3850	3850	3975	4050	4200	-	-	3°-6°
S600	6000	4400	5400	6400	7000	8000	4100	4100	4225	4300	4450	-	-	3°-6°	
2-STAGE FULL FREE MAST	D250	2500	5000	6000	7000	8000	-	2185	2185	2185	2390	-	1270	1270	6°-12°
	D270	2700	5000	6000	7000	8000	-	2310	2310	2310	2500	-	1370	1370	6°-12°
	D300	3000	5000	6000	7000	8000	10000	2460	2460	2460	2650	2800	1520	1520	6°-12°
	D330	3300	5000	6000	7000	7000	8000	2610	2610	2610	2800	2950	1670	1670	6°-12°
	D350	3500	5000	6000	7000	7000	8000	2710	2710	2710	2900	3050	1770	1770	6°-12°
	D375	3750	5000	6000	6500	7000	8000	2835	2835	2835	3025	3175	1895	1895	6°-12°
	D400	4000	5000	6000	6500	7000	8000	3010	3010	3010	3200	3350	2070	2070	6°-12°
	D425	4250	5000	6000	6500	7000	7500	3135	3135	3135	3325	3475	2195	2195	6°-12°
	D450	4500	5000	6000	6500	7000	7500	3260	3260	3260	3450	3600	2320	2320	6°-12°
	D475	4750	5000	6000	6500	7000	7500	3385	3385	3385	3575	3725	2445	2445	6°-6°
	D500	5000	5000	6000	6000	7000	7500	3510	3510	3510	3700	3850	2570	2570	6°-6°
	D550	5500	4750	5700	6000	6800	7000	3810	3810	3810	4000	4150	2870	2870	3°-6°
D600	6000	4400	5400	5800	6800	6500	4060	4060	4060	4250	4400	3120	3120	3°-6°	
3-STAGE FULL FREE MAST	T360	3600	4500	5600	6500	7000	8000	2335	2335	2335	2450	2570	1300	1290	6°-12°
	T400	4000	4500	5600	6500	7000	8000	2470	2470	2470	2575	2700	1420	1415	6°-12°
	T435	4350	4500	5600	6000	7000	8000	2585	2585	2585	2700	2820	1550	1540	6°-12°
	T480	4800	4500	5600	6000	7000	7500	2740	2740	2740	2850	2970	1700	1690	6°-6°
	T500	5000	4500	5600	6000	7000	7500	2805	2805	2805	2950	3035	1800	1790	6°-6°
	T540	5400	4200	5300	5800	6600	7000	2940	2940	2940	3075	3225	1920	1915	3°-6°
	T600	6000	4000	5000	5500	6000	6000	3140	3140	3140	3375	3425	2220	2215	3°-6°

PS: 10t Full Free 3 Stage Mast is with Side Shifter.

Fork standard													
Model	Standard(mm)	Width (mm)	Thickness (mm)	Length (mm) L1									
5t	1220x150x55	150	55	*1220	1370	1520	1670	1820	1970	2120	2270	2420	2570
6t	1220x150x60	150	60	*1220	1370	1520	1670	1820	1970	2120	2270	2420	2570
7t	1220x150x65	150	65	*1220	1370	1520	1670	1820	1970	2120	2270	2420	2570
8t	1220x170x70	170	70	*1220	1370	1520	1670	1820	1970	2120	2270	2420	2570
10t	1220x175x80	175	80	*1220	1370	1520	1670	1820	1970	2120	2270	2420	2570

Standard equipment >>>

- Hour meter
- Oil pressure alarm
- Hydraulic filter
- Lamp guard
- Charge director
- Back-up buzzer
- Hydraulic steering
- Standard fork
- Drawbar pin
- Horn
- Back-up alarm
- Rear working light
- 2-stage mast
- Awning
- Standard seat

Option >>>

- Cabin
- High exhaust
- Suspend seat
- Fork extension
- Soft tire
- Windshield
- Heater
- Wider fork carriage
- Anti-fire muffler
- Customer color
- Lifting hook
- Carpet probe
- Side shifter
- Job



Please read the operating manual closely before you drive the forklift, in order to make sure you operating feeler forklift conveniently and freely. Feeler forklift continually renew and improve the products, thus maybe some function and model is different from the catalogues.

Attachments for Forklifts

Please note that the units below are for illustration purposes only.



SIDESHIFT



SIDESHIFTING FORK POSITIONER



FORK POSITIONER



GENERAL PURPOSE CLAMP



BALE CLAMP



ROTATING PALLET FORK CLAMP



DUAL PALLET HANDLER



DRUM CLAMP



LOAD INVERTER



FREE STANDING LOAD INVERTER



ROTATOR



180 DEGREE ROTATOR



"EXTENDAFORK"

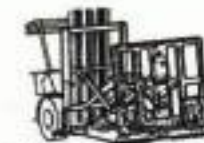

PUSH/PULL ATTACHMENT



SCOOP



LOAD STABILISER



TILTING CARRIAGE



CARPET PROBE



EXTENSION SLIPPERS



HOSE REEL



FORKS-HOOK TYPE



FORKS-PIN TYPE



KPF-PIVOT FRAME



KPR PAPER ROLL CLAMPS



CPR-PIVOT FRAME



CPR-PAPER ROLL CLAMP

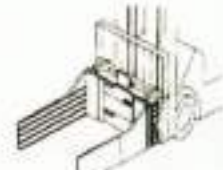

PULP BALE CLAMP



友佳國際控股
杭州友高精密機械有限公司

HANGZHOU GLOBAL FRIEND PRECISION MACHINERY CO., LTD.

ADD: NO. 431, 14th Street Hangzhou Economy & Technology Development Area, Zhejiang, China

TEL: +86-571-86853366

FAX: +86-571-8685-3018

<https://www.forklift360.com>



友嘉集團
FOR FRIEND INT. GROUP

For detailed specification,
please telephone dealer.

2006.3.5

FEELER FORKLIFT

Features >>>

Counter Balance diesel forklift (5-10ton)

Indoor and outdoor forklift operator



Perfect design for front and rear hoisting position
Ensures convenient swing and load or unload



Front hoisting point
Rear hoisting point

A full security



Complete shut-off cabin (option)
Air conditioning, heater, audio (option)



Do
Spe
Con



Completely appearance design
Exquisite & elegant appearance



Hydraulic brake system
Quick response and high sensitivity



Integrative high strength
"C" conduit steel mast
Improves strength and capacity



Hydraulic transmission
Large torque and high reliability
Adopt Taiwan Tongyi battery with high quality and efficiency

(Example: FD50TA)



Lifting speed (with out load)
500MM/S

Travel speed (with out load)
28KM/H



Auto electronic gear system
Easy gear and convenient operation



Succint & beautiful floor design



Large turning degree
Ensures smaller turning radius (outer)



Front dual tire design
Improves the operating safety



Warning equipment for backward
Backward light design
Convenient work in large area at night



Wide-view mast
Safe operation



Outer air filter (dual-filter)
Ensures cleaner air supplement for engine